

YMCA CAMP FULLER SAILING ASSOCIATION

Intermediate Sailing Test

* * *

Name: _____ Instructor: _____

Part One: Identify the following parts of the sailboat.

1. Grommets _____
2. Shackle _____
3. Fairlead _____
4. Gooseneck _____
5. Boltrope _____
6. Spreaders _____
7. Outhaul _____
8. Boom Vang _____
9. Shroud _____
10. Traveler system _____

Part Two: Using the diagram, identify the parts of the boat with spaces next to them.

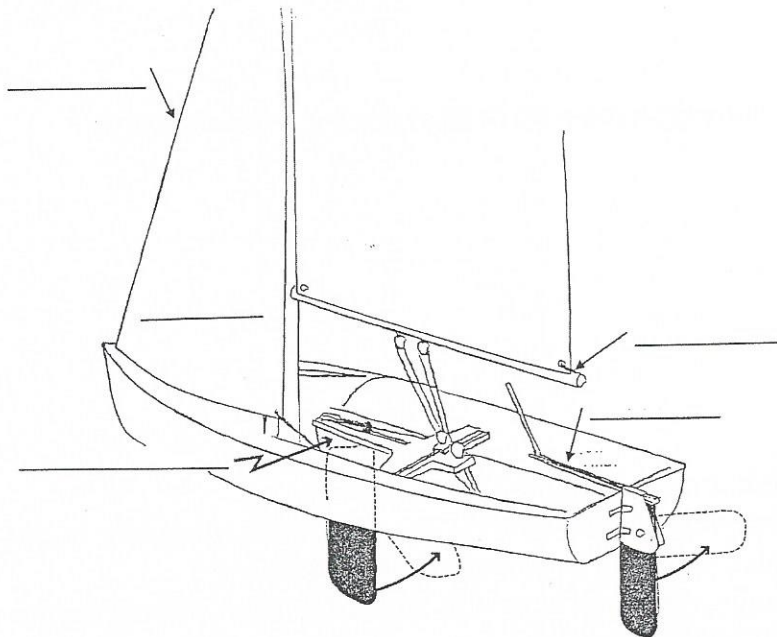

Part Three: Identify which part of the boat the following definitions describe:

1. Sitting area in the boat: _____
2. Piece that holds sheets in place after being hauled in: _____
3. Foothold allowing the crew to lean weight over the windward side to flatten the boat: _____
4. Metal loops sewn into the corners of the sail: _____
5. Line that secures boats to docks/moorings: _____

Part Four: Briefly describe the mooring process, using a diagram if necessary.

Part Five: List five things you must do before righting a capsized boat.

- 1.
- 2.
- 3.
- 4.
- 5.

Part Six: Circle whether each statement is true or false.

- You must always be moving directly into the wind to properly moor (T / F)
- It is best to pick up a man overboard on a reach (T / F)
- If you are coming into a docking with too much speed, pulling in your sails will slow your boat down (T / F)

Part Seven: Using the diagram fill in the point of sail and show proper sail trim.

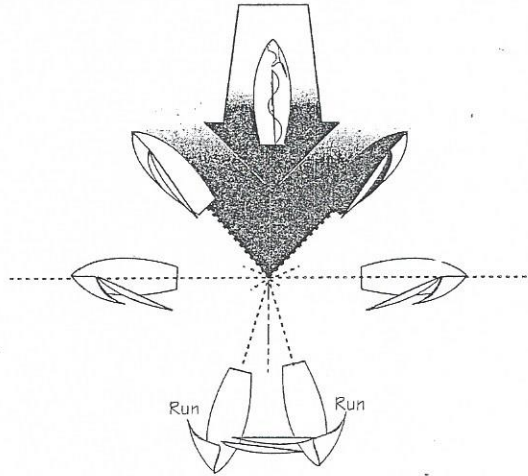

Part Eight: Describe "wing on wing".

EXTRA CREDIT: Explain what "pinching" is. Is it good or bad? What point of sail does it occur on?